



Non-Confidential Description  
**Novel Multi-Frequency Quadrature Signal Correction Method**  
 Technology Case: RFT-46

### Invention Summary

Scientists at North Dakota State University have developed a unique method for detecting and correcting the vector mismatches inherent in quadrature receivers. This method uses a periodic multi-frequency calibration signal to detect the mismatches and then dynamically adjusts the system response to correct the mismatches in real-time.

### Benefits

- Corrects time-varying vector mismatches in quadrature signals across *multiple frequencies*.
- Improved signal quality and reliability over conventional mismatch determination systems.
- Updates on demand or continuously.
- Useful applications in telecommunications and quadrature receiver systems (wireless communications, cell phones, radios, etc.).

### Invention Premise

The multi-frequency system enables a signal processing system to determine vector mismatches between numerous signal paths. By broadcasting a multi-tone, multi-frequency calibration signal and comparing it to an ideal waveform mathematically generated in the receiver, the method can detect mismatches across multiple frequencies, distinguishing it from conventional mismatch determination systems. Periodic calibration signals are used to adapt the system performance dynamically, allowing the correction of time-varying mismatch errors. This multi-frequency detection and correction improves signal quality and reliability, and includes assessments of in-phase and quadrature signal paths, as well as vector

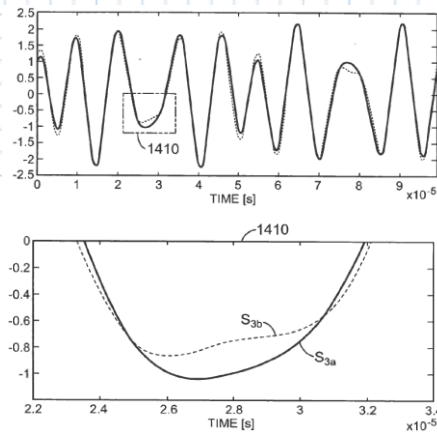
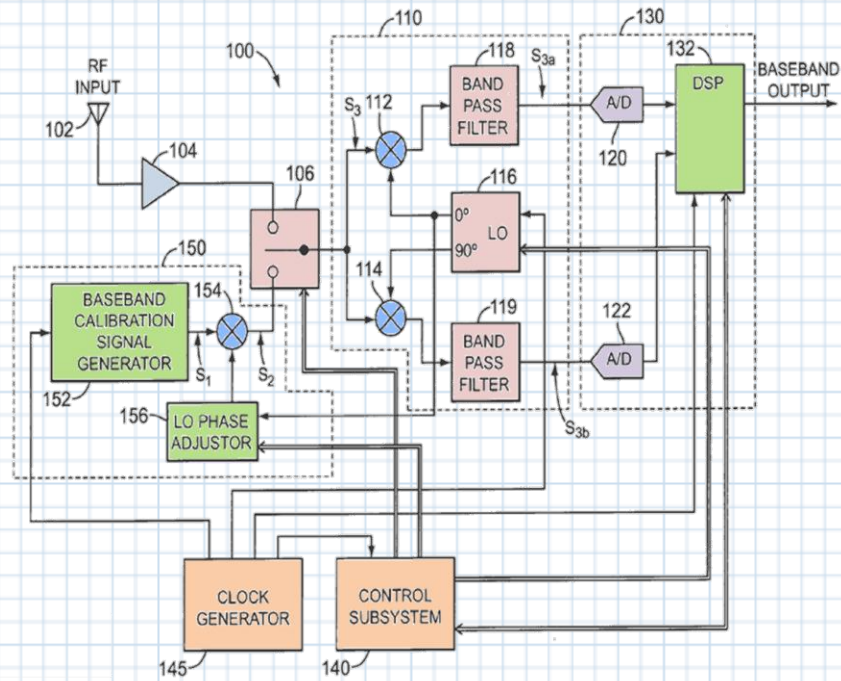

Figure (above) showing one embodiment of a multi-frequency quadrature signal correction system, as well as graphs (left) showing a typical example of a signal exhibiting both phase and amplitude vector mismatch.

mismatch between array elements. The system includes the capability of test signal injection at the RF (Radio Frequency) stage, which allows the detection and correction of mismatch in RF-to-IF (Intermediate Frequency) components.

## Patents

This technology is the subject of issued US Patent 7,088,765, as well as a US pending application as described in US Patent Publication 2006-0262872 A1. The technology is available for licensing/partnering opportunities.

## The Lead Inventor



### **Roger Green**

Associate Professor, Electrical Engineering

Dr. Green obtained his Ph.D. in Electrical Engineering from the University of Wyoming after completing his dissertation, entitled "Space-Time Evolutionary Fourier Analysis". At the same time, he obtained a graduate minor in statistics. Prior to his Ph.D. work, Dr. Green earned M.S. and B.S. degrees in Electrical Engineering from the University of Wyoming in 1994 and 1992, respectively.

Currently, Dr. Green's professional research interests focus on digital and statistical signal processing, time series analysis, spectral and time-frequency analysis, array processing, real-time systems, and data adaptive techniques. In the fall of 2004, Dr. Green established the Digital Signal Processing (DSP) scholar-team. This team, comprised of both undergraduate and graduate students, has engaged in a variety of hands-on DSP activities including the design, fabrication, and implementation of a custom DSP board for audio processing applications.

## Inquiries

Jonathan Tolstedt, Licensing Associate/Patent Agent  
NDSU Research Foundation, Fargo, ND 58108-6050  
Phone: 701-231-8173 Fax: 701-231-6661  
Email: [jtolstedt@ndsurf.org](mailto:jtolstedt@ndsurf.org)  
Web: [www.ndsuresearchfoundation.org](http://www.ndsuresearchfoundation.org)