



Non-Confidential Description
**Environmentally Safe Device for the Detection
of Explosives and Hazardous Chemicals**
Technology Case: RFT-166

Invention Summary

Scientists at North Dakota State University have developed a unique, cost-effective, and environmentally friendly security detection device that is capable of identifying a wide array of explosives, toxic products, pollutants, and hazardous materials.

Building upon the concept of Ion Mobility

Spectrometry (IMS) screening technology, this device has improved sensitivity and can monitor samples in ambient air. The improved sensitivity

also allows the device to reduce the number of false positive alerts. Simplified electronic components and the use of a photo-emissive source instead of a radioactive source allow units to be manufactured as a lower cost and without hazardous components.

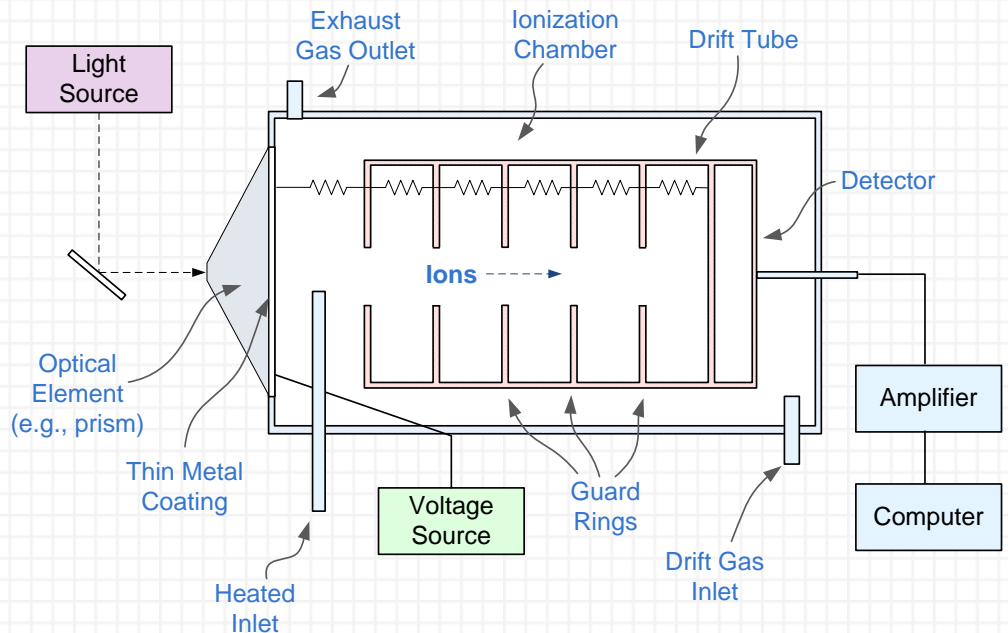

Figure 1: Schematic of Hazardous Chemical Detection Device

Benefits

- **GREEN TECHNOLOGY!** Eliminates the need for radioactive components
- Improved sensitivity and a wider range of detectable compounds
- Immediate commercial applications exist in the areas of environmental clean-up and homeland security, including fixed site, transportation, border, and environmental screening for electronegative species or matter such as:
 - Nitrate-based explosives
 - Barbiturates
 - Chlorinated solvents (ground water pollutants)
 - Many pesticides and some types of tear gas
- Demonstrated capability in reducing false positive alerts
- Ability to monitor and detect samples in ambient air
- Capability to detect compounds beyond immediate contact to the detection surface
- Simplified electronics supports lower manufacturing cost



Invention Premise

Referring to Figure 1 on the previous page, a beam of light impinging on an optical element such as a prism is directed onto a thin metal coating, which generates the photoemission of free, low-energy electrons. A sample containing suspected explosives or hazardous chemicals is injected into the device through a heated inlet. The gas sample interacts with the flow of electrons and creates ions. The ions then pass into a drift tube consisting of multiple sets of guard rings which facilitate movement of the ions through the drift tube. As the ions pass through the drift tube, an electric field generated by the rings separates the ions based on their mobility (that is, their mass, size, and shape). This causes the ions to arrive at the back wall of the drift tube, which contains an ion detector, in order from fastest to slowest, generating a response signal characteristic of the chemical composition of the measured sample.

Patents

This technology is patented with fully preserved US patent rights (issued US patent 7,304,298 B2), and is available for licensing/partnering opportunities.

The Lead Inventor



Orven, Swenson, Ph.D.

Associate Professor
Department of Physics

Dr. Orven Swenson received both his Bachelor of Science and Master of Science in Physics from North Dakota State University. He received his Doctorate in Laser Optics from the Air Force Institute of Technology. Dr. Swenson's research interests include optics education, laser sintering of direct write materials, imaging of aerosols in flows, photoemissive-ionization ion mobility spectroscopy for the detection of explosives and hazardous materials, microchip laser-pumped tunable dye lasers, and tunable fiber laser development.

Inquiries

Jonathan Tolstedt, Licensing Associate/Patent Agent
NDSU Research Foundation, Fargo, ND 58108-6050
Phone: 701-231-8173 Fax: 701-231-6661
Email: jtolstedt@ndsurf.org
Web: www.ndsuresearchfoundation.org